

AUX

CATALOGUE
HEAT PUMPS
2025



CONTENTS

About AUX Group	4
Sustainable Development	8
Energy from Nature	10
How Does a Heat Pump Work?	12
Applications	14
Why Choose an AUX Heat Pump?	16
Features and Functions	18
Funding	26
Technical Specifications	30
Dimensional Drawings	34





AUX - ABOUT THE BRAND

A NEW DIMENSION OF QUALITY

The AUX Group, present in global markets for 36 years, is recognised as one of the leading manufacturers in the sectors of real estate, finance, electronics, and smart household appliances. It boasts a powerful production infrastructure, including automated factories, research and development centres, and a highly skilled workforce.

HVAC systems form a strong pillar of the group's operations, and the continuous and dynamic growth in sales volume has placed the AUX brand among the top three in China's air conditioning industry.

The AUX Group places great emphasis on sustainable development, ensuring the responsible and thoughtful use of resources to secure prosperity for both present and future generations. In its laboratories, the company develops patented technologies focused on continuous optimisation and improvement in the areas of ecology, energy efficiency, and performance.

Aligned with the concept of sustainable development is a commitment to human health and improving the quality of the air we breathe.

36

YEARS OF EXPERIENCE

180

COUNTRIES

11

FACTORIES

AUX

Brand trusted by millions

AUX - ABOUT THE BRAND

PRODUCT RANGE

ROOM AIR CONDITIONERS

AUX room air conditioners include as many as 8 unique wall-mounted models. All units feature sophisticated design and the most comprehensive range of functions in their class.

COMMERCIAL AIR CONDITIONERS

AUX air conditioning systems are an excellent choice for commercial spaces. Wall-mounted, cassette, ducted, and floor-ceiling units allow for the creation of a complete and discreet air conditioning system in any room.

MULTI AIR CONDITIONERS

AUX offers multi-split air conditioning solutions, which are gaining increasing popularity in Poland. Multi-split systems are perfect for homes, apartments, shops, small hotels, and service facilities.

ARV SYSTEMS

The ARV7 is AUX's latest-generation system. These highly advanced technological units are an ideal solution for commercial buildings, offices, hotels, and residential buildings (ARV Mini).

AUX HEAT PUMPS

Air-to-water heat pumps are a new addition, directly addressing the evolving market demands. AUX Group has designed intelligent and reliable devices that provide an energy-efficient, comprehensive home heating system.



6
RESEARCH
AND DEVELOPMENT CENTRES

30
THOUSANDS
OF EMPLOYED WORKERS

AUX An expert in delivering
energy-efficient solutions



SUSTAINABLE

DEVELOPMENT

As one of the leading manufacturers of advanced air conditioning systems and heat pumps, the AUX Group takes sustainable development very seriously. One of its key pillars is environmental responsibility. AUX's brand policy is based on the idea of using natural resources rationally, ensuring prosperity for both present and future generations.

Teams of highly qualified engineers working in AUX research centres worldwide are constantly seeking energy-efficient, intelligent, and eco-friendly technological solutions. By integrating these innovations into production processes, AUX contributes to sustainable development while delivering cleaner and better air.



AUX cares about the quality
of the air you breathe

FOR
A BETTER TOMORROW

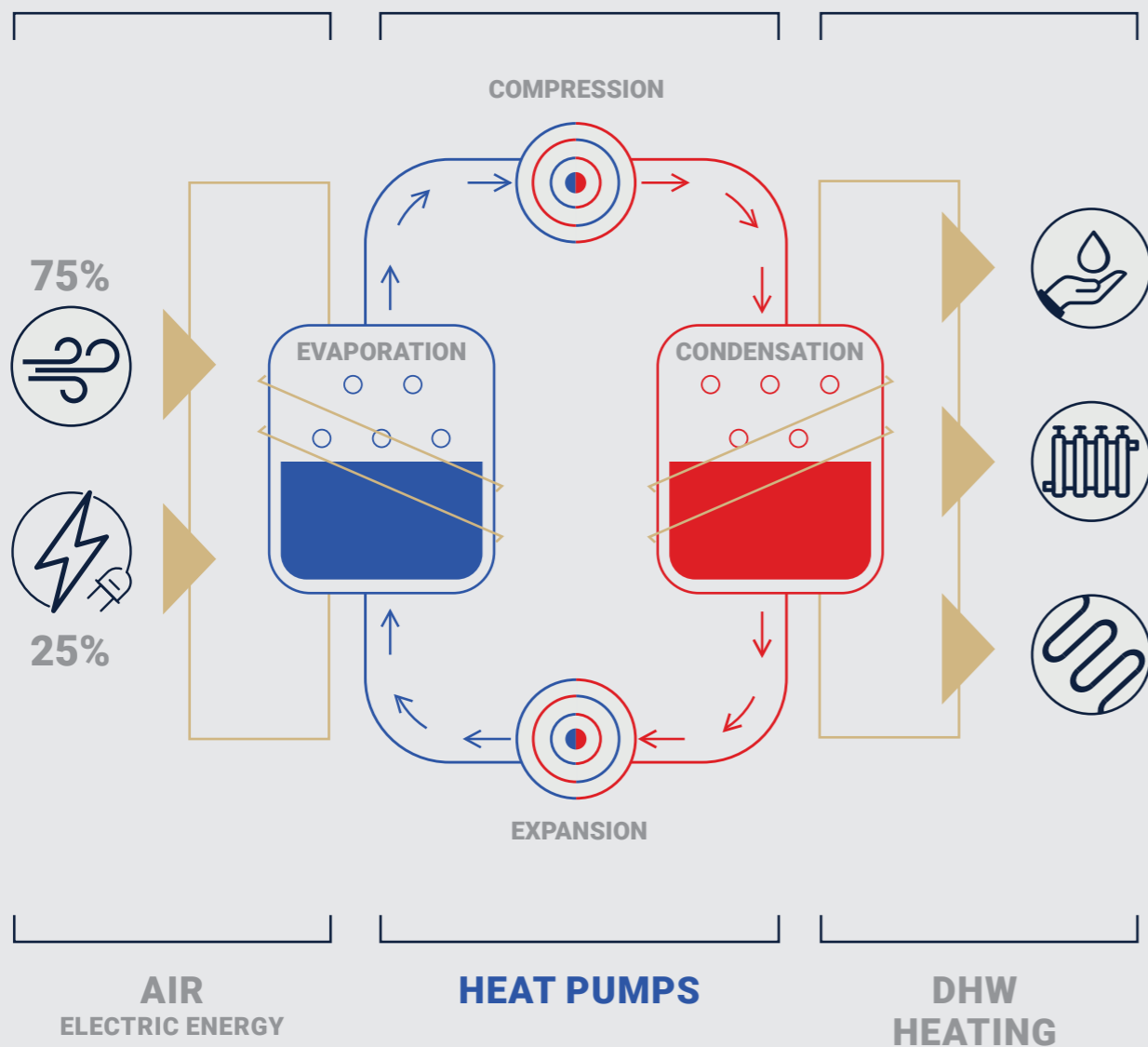

ENERGY

FROM NATURE

A heat pump utilises up to 75% of free energy from the air, with only 25% coming from electricity. In practice, this means the device extracts heat from the outdoor air and, with minimal electricity consumption, transfers it into the building.

The energy efficiency of heat pumps is measured by the COP (Coefficient of Performance), which indicates the ratio of heat delivered to the amount of electricity consumed. The higher the COP, the greater the energy efficiency. A higher energy efficiency ratio translates to better performance and, consequently, greater savings.

A heat pump is one of the most cost-effective and environmentally friendly heating systems available.



AUX

75% Free Energy from the Environment

HOW DOES A HEAT PUMP WORK?

The vast majority of air-to-water heat pumps are classified as renewable energy sources and are currently considered the most efficient heating technology. An air-to-water heat pump utilises heat accumulated in the air for heating, cooling, and domestic hot water production.

Despite common misconceptions, the operation of a heat pump is not complicated and is based on a well-known mechanism used, for example, in refrigerators. The key components of a heat pump include a compressor, expansion valve, condenser, and evaporator. The entire process is made possible by the refrigerant.

The refrigerant is a liquid that circulates within the system, boiling at low pressure and temperature while absorbing heat from the surroundings. Next, the pressure and temperature increase, and the refrigerant transforms into a gas due to the compressor. It then moves to the condenser, where it releases heat into the heating system. After this, the refrigerant, now in liquid form, passes through the expansion valve, where its pressure and temperature drop, restarting the cycle.

If the heat pump has an integrated cooling function, the process works in reverse – the refrigerant extracts heat from the water and releases it outside.

**A heat pump
is the best
choice!**



The most important factors defining heat pump efficiency



COP

Coefficient of Performance

The coefficient of performance (COP) defines the ratio of the amount of heat energy delivered by the heat pump to the amount of energy it consumes. If a heat pump has a COP of 5, it means that to generate 5 kW of heat, the device uses only 1 kW of electricity.

SCOP

Seasonal Coefficient of Performance

The Seasonal Coefficient of Performance (SCOP) allows for calculating the amount of electricity consumed over a year or heating season. This makes it easy to estimate the cost of heating a building with a heat pump.

EER

Energy Efficiency Ratio

The Energy Efficiency Ratio (EER) defines the ratio of the amount of cooling energy delivered by the heat pump to the amount of energy it consumes. If a heat pump has an EER of 5, it means that to generate 5 kW of cooling, the device uses only 1 kW of electricity.

SEER

Seasonal Energy Efficiency Ratio

The Seasonal Energy Efficiency Ratio (SEER) allows for calculating the amount of electricity consumed over a year or cooling season. This makes it easy to estimate the cost of cooling a building with a heat pump.

The higher the SCOP and SEER values
the lower the electricity bills



floor heating

radiator

fan coil

WORKS
**WITH THE HEAT
EMITTERS**

Air-to-water heat pumps work with heat emitters such as fan coil units, radiators, or underfloor heating systems. However, using low-temperature heat emitters is the most efficient option. Surface heating systems have a large surface area, which means they do not require high temperatures like point heat sources.

WHY CHOOSE AN AUX HEAT PUMP?



A complete heating system

Heats, cools the building, and provides domestic hot water



Complete safety

No risk of fire, explosion, or carbon monoxide poisoning



Maintenance-free operation

No need for cleaning, igniting, or constant monitoring of the device



Ecology

Operation does not emit harmful substances into the environment



Peace and quiet

Quiet operation ensures high user comfort



Aesthetics

No need to install radiators, which often compromise interior aesthetics



Versatile application

Designed for new buildings and thermal modernisation projects



Easy and quick installation

The estimated installation time by an experienced company is approximately 1-3 days



Savings

Free energy from the air and the possibility of integration with a photovoltaic system



Long lifespan

The average lifespan of a heat pump is estimated to be 20 years.

FEATURES AND FUNCTIONS

OF THE AUX HEAT PUMP



Surface heating



R32 refrigerant



DHW setting up to 60°C



Inverter technology



Energy efficiency A+++



Fast DHW



Sterilisation capability up to 65°C



Automatic water temperature adaptation



ECO mode



Holiday mode



Quiet operation



SG Ready



Safety



Certificates



Emission-free



Maintenance-free



Quick installation



Versatile application



Low operating cost



Wi-Fi module

Surface heating

Compatible with low-temperature underfloor, wall, and ceiling heating systems

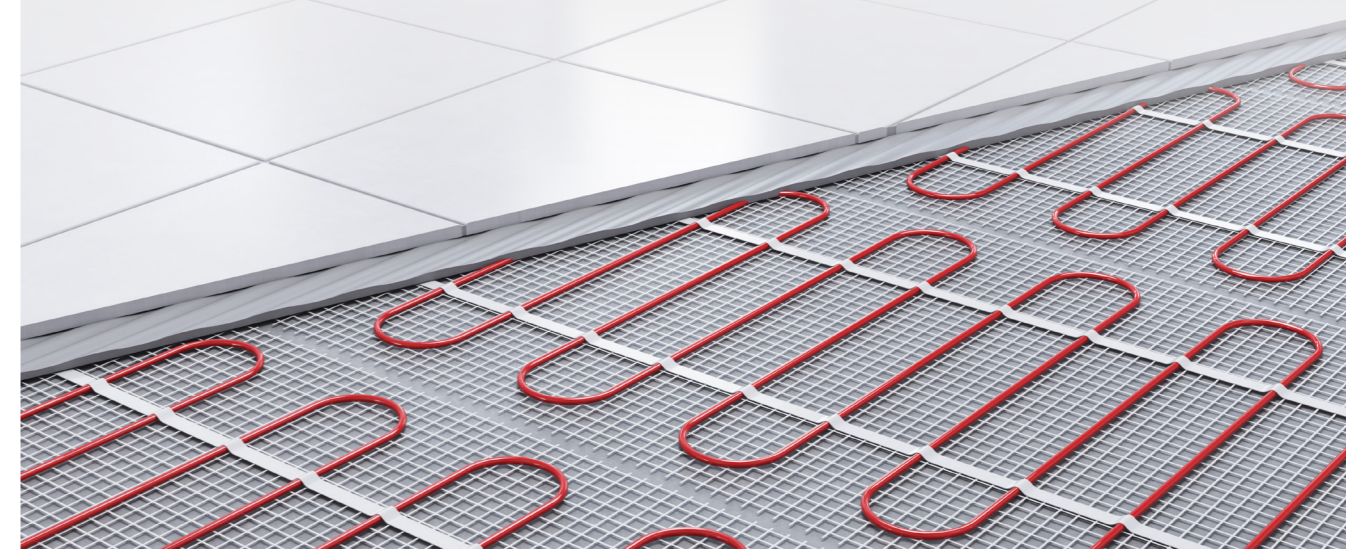

R32 refrigerant

Operates using R32, the most environmentally friendly refrigerant currently available



AUX

AUX develops and implements innovative technologies

Domestic hot water up to 60°C

Provides domestic hot water, reaching temperatures of up to 60°C.



Inverter technology

Inverter technology enables smooth performance adjustment without compromising the device's efficiency.



Fast DHW

The Fast DHW function quickly meets the demand for hot water.



Energy efficiency A+++

A high energy efficiency class of A+++ guarantees energy savings.



Sterilisation at 65°C

The high sterilisation temperature ensures 99% effectiveness in eliminating Legionella bacteria, which can multiply in DHW tanks when hot water is not used for an extended period. Proper operation requires an additional TBH heater.



Automatic water temperature

The heat pump automatically determines and sets the optimal water temperature for maximum comfort.



ECO mode

Eco mode saves up to 50% energy.



Holiday mode

The holiday function protects the device from potential damage caused by factors such as frost.

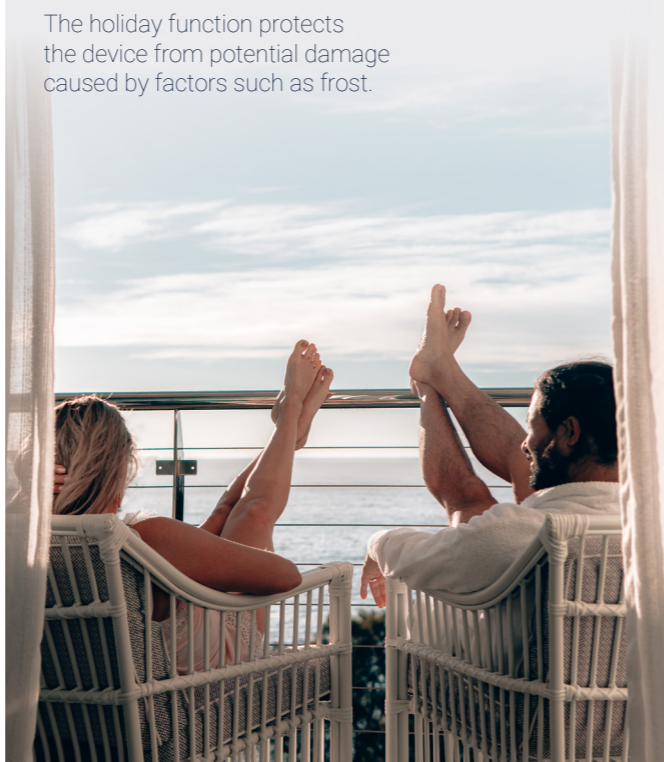

Safety

Heating your home with a heat pump poses no risk of explosion or carbon monoxide leakage. The heat pump operates without emitting carbon dioxide.



Quiet operation

The outdoor unit operates at a noise level below 45dB, while the indoor unit remains quieter than 31dB.



SG Ready

The SG Ready label is assigned to heat pumps whose regulation allows the integration of a single heat pump with a smart energy grid.



Certificates

The AUX heat pump holds the KEYMARK certification, confirming compliance with European standards, as well as a hygiene certificate.



Emissions-free

The heat pump is a device that does not emit any pollutants into the environment, making it an eco-friendly alternative to traditional heating methods.



Maintenance-free

The heat pump is a virtually maintenance-free system, allowing for significant time savings.



Low operating cost

The operating cost of a heat pump is really low, primarily due to the high energy efficiency of the device.

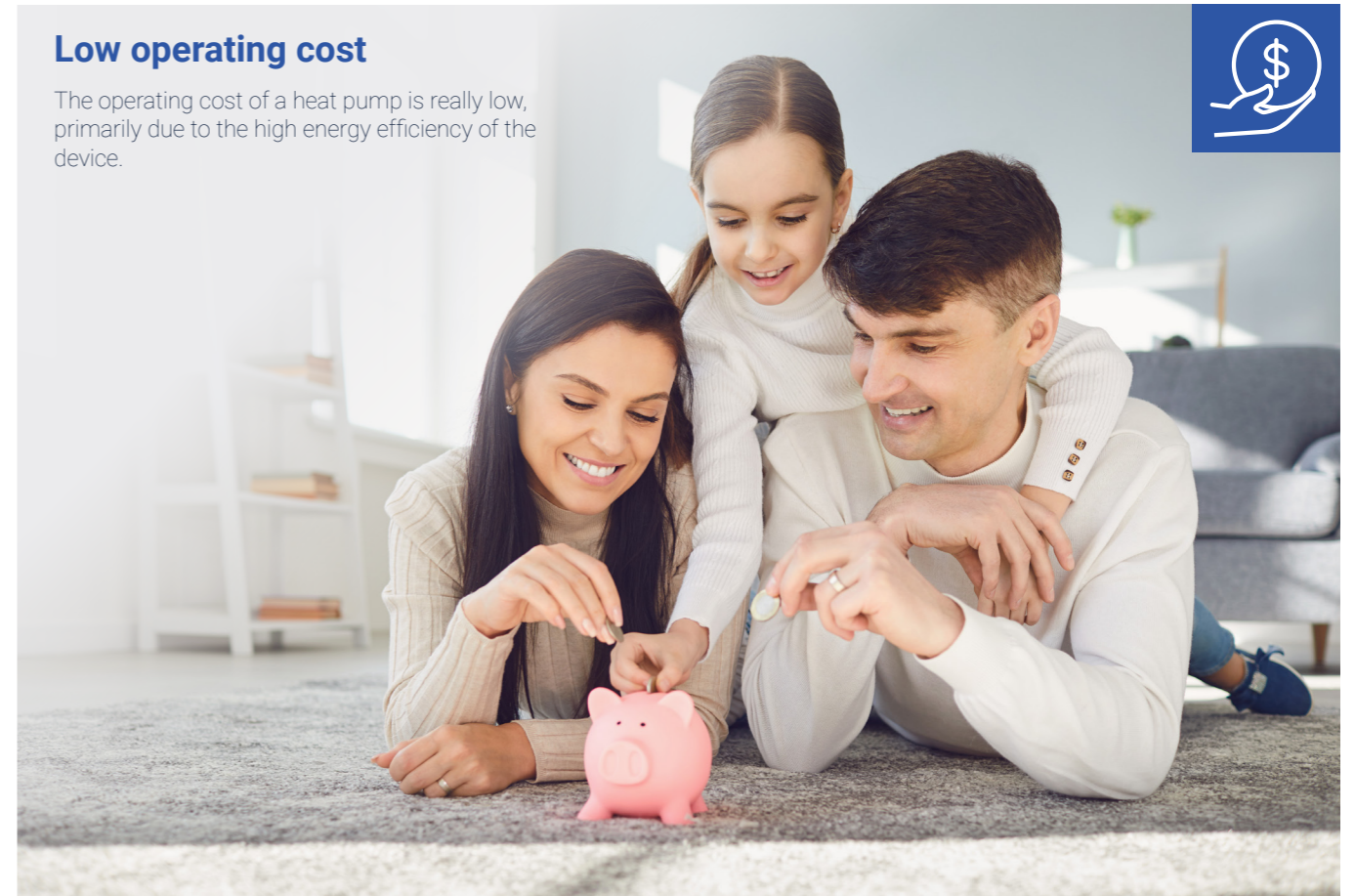

Quick installation

The installation of an air-source heat pump is relatively quick and straightforward, usually taking between 2 to 3 days.



Versatile application

It is compatible with various heat emitters (underfloor heating, radiators, fan coil units) and can operate in bivalent systems with other heat sources such as a gas boiler or electric heaters.



Wi-Fi module

The Wi-Fi module ensures easy and convenient control via the app.



FUNDING

MY WARMTH (MOJE CIEPŁO)

The „Moje Ciepło” programme provides subsidies for the purchase and installation of heat pumps in single-family homes. The subsidies range from 7,000 to 21,000 PLN and are intended to cover up to 30% of eligible investment costs, or up to 45% for holders of the Large Family Card. The „Moje Ciepło” initiative aims to encourage investment in renewable energy sources, specifically in the development of heating systems that use zero-emission heat sources in single-family homes. According to NFOŚiGW, the „Moje Ciepło” programme will run until 2026. The budget for the programme, funded by the Modernisation Fund, amounts to 600 million PLN.

The programme is targeted at individuals who are the owners or co-owners of new single-family residential buildings.

The „Moje Ciepło” programme supports the purchase and installation of heat pumps in new homes and complements the „Czyste Powietrze” programme, which provides financial support for thermomodernised buildings.



What does „New house” mean

in the understanding of the „Moje Ciepło” Programme?

A „new house” is one that meets one of the following conditions:

- The notification of completion of construction was submitted no earlier than 1 January 2021.
- On the date of submitting the application for the grant, no notification of the completion of a single-family residential building has been submitted, or no application for a decision on the issuance of a permit for use has been submitted in accordance with the provisions of the Construction Law Act of 7 July 1994.

What should be done

to receive funding?

- You must purchase and install a heat pump in the new house.
- The device should be purchased between 1 January 2021 and 31 December 2026.
- You must choose a device with an enhanced energy standard. This means that the value of the annual non-renewable primary energy indicator (EP) for heating, ventilation, and hot water for domestic use may not exceed 63 kWh/(m² per year) in the first year of operation, i.e. in 2022. In subsequent years, the requirement for the EP indicator will be no more than 55 kWh.

FUNDING

CLEAN AIR (CZYSTE POWIETRZE)

Clean Air Programme – a nationwide financial support programme for replacing heat sources. The programme is for owners and co-owners of single-family homes, offering subsidies for replacing the heat source and performing energy efficiency works. The aim of the programme is to improve air quality and reduce greenhouse gas emissions through the replacement of heat sources and the improvement of energy efficiency in single-family residential buildings.

The Clean Air Programme is directed towards owners or co-owners of single-family residential buildings, or residential premises separated within single-family buildings with a separate land and mortgage register.

Applications for funding can be submitted online or at the office. For more information, visit: www.czystepowietrze.gov.pl



Twój wybór!

Scope of support

in the Clean Air programme

Funding for the replacement of old and inefficient solid fuel heat sources with modern heat sources that meet the highest standards, as well as carrying out necessary energy efficiency works on the building.

The amount of funding

in the Clean Air programme

- Basic level: up to 30,000 PLN
- Enhanced level: up to 37,000 PLN / up to 47,000 PLN (grant with pre-financing)
- Highest level: up to 69,000 PLN / up to 79,000 PLN (grant with pre-financing)

TECHNICAL SPECIFICATIONS



Model name		ACHP-H04/4R3HA	ACHP-H06/4R3HA	ACHP-H08/4R3HA
Outdoor unit		ACHP-H04/4R3HA-O	ACHP-H06/4R3HA-O	ACHP-H08/4R3HA-O
Indoor unit		ACHP-H04/4R3HA-I	ACHP-H06/4R3HA-I	ACHP-H08/5R3HA-I
Heating (A7/W35) (1)	Capacity kW	4,30	6,25	8,40
	Power consumption kW	0,83	1,30	1,62
	COP	5,20	5,00	5,20
Heating (A7/W55) (2)	Capacity kW	4,36	6,40	8,30
	Power consumption kW	1,47	2,13	2,60
	COP	2,96	3,00	3,19
Cooling (A35/W18) (3)	Capacity kW	4,50	6,60	8,45
	Power consumption kW	0,81	1,35	1,67
	EER	5,56	4,90	5,06
Cooling (A35/W7) (4)	Capacity kW	4,75	7,05	7,45
	Power consumption kW	1,40	2,35	2,20
	EER	3,40	3,00	3,39
Seasonal energy efficiency class: heating (6)	LWT 35°C	A+++	A+++	A+++
	LWT 55°C	A++	A++	A++
SCOP (6)	LWT 35°C	4,86	4,96	5,22
	LWT 55°C	3,32	3,53	3,37
Power supply	Outdoor unit V~/Hz	220-240/1/50	220-240/1/50	220-240/1/50
	Indoor unit V~/Hz	220-240/1/50	220-240/1/50	380-415/3/50
Maximum overcurrent protection	A	18	18	19

We reserve the right to errors in descriptions, appearance, functions, technical parameters, and dimensional drawings resulting from the continuous improvement of our devices.

Model name		ACHP-H10/4R3HA	ACHP-H12/5R3HA	ACHP-H14/5R3HA	ACHP-H16/5R3HA
Outdoor unit		ACHP-H10/4R3HA-O	ACHP-H12/5R3HA-O	ACHP-H14/5R3HA-O	ACHP-H16/5R3HA-O
Indoor unit		ACHP-H10/5R3HA-I	ACHP-H12/5R3HA-I	ACHP-H14/5R3HA-I	ACHP-H16/5R3HA-I
Heating (A7/W35) (1)	Capacity kW	10,00	12,20	14,5	16,10
	Power consumption kW	2,00	2,44	3,08	3,57
	COP	5,00	5,00	4,71	4,51
Heating (A7/W55) (2)	Capacity kW	10,00	12,00	14,00	16,1
	Power consumption kW	3,23	3,86	4,67	5,53
	COP	3,10	3,11	3,00	2,91
Cooling (A35/W18) (3)	Capacity kW	10,00	12,00	13,60	15,00
	Power consumption kW	2,08	3,00	3,78	4,41
	EER	4,80	4,00	3,60	3,40
Cooling (A35/W7) (4)	Capacity kW	8,30	11,70	12,80	14,00
	Power consumption kW	2,52	4,30	5,00	5,70
	EER	3,30	2,75	2,56	2,46
Seasonal energy efficiency class: heating (6)	LWT 35°C	A+++	A+++	A+++	A+++
	LWT 55°C	A++	A++	A++	A++
SCOP (6)	LWT 35°C	5,20	4,82	4,71	4,63
	LWT 55°C	3,50	3,46	3,48	3,43
Power supply	Outdoor unit V~/Hz	220-240/1/50	380-415/3/50	380-415/3/50	380-415/3/50
	Indoor unit V~/Hz	380-415/3/50	380-415/3/50	380-415/3/50	380-415/3/50
Maximum overcurrent protection	A	19	14	14	14

(1) Outdoor temperature 7°C DB, 85% R.H.; EWT 30°C, LWT 35°C. (2) Outdoor temperature 7°C DB, 85% R.H.; EWT 40°C, LWT 45°C. (3) Outdoor temperature 7°C DB, 85% R.H.; EWT 47°C, LWT 55°C. (4) Outdoor temperature 35°C DB, EWT 23°C, LWT 18°C. (5) Outdoor temperature 35°C DB, EWT 12°C, LWT 7°C. (6) Seasonal energy efficiency class measured under average climate conditions. Relevant EU standards and regulations: EN14511, EN14825, EN50564, EN112102.

We reserve the right to errors in descriptions, appearance, functions, technical parameters, and dimensional drawings resulting from the continuous improvement of our devices.

Model name			ACHP-H04/4R3HA	ACHP-H06/4R3HA	ACHP-H08/4R3HA	
Outdoor unit			ACHP-H04/4R3HA-O	ACHP-H06/4R3HA-O	ACHP-H08/4R3HA-O	
Indoor unit			ACHP-H04/4R3HA-I	ACHP-H06/4R3HA-I	ACHP-H08/5R3HA-I	
Compressor	Type	-	Dual rotary DC Inverter	Dual rotary DC Inverter	Dual rotary DC Inverter	
	Motor type	-	Brushless DC motor	Brushless DC motor	Brushless DC motor	
External unit fan	Number of fans	-	1	1	1	
	R32 refrigerant	Quantity	kg	1,10	1,10	1,45
Type of expansion valve		-	Electronic	Electronic	Electronic	
Refrigeration system	Diameter of the liquid/gas connection	mm	Φ9.52/15.9	Φ9.52/15.9	Φ9.52/15.9	
	Min/ max installation length	m	2/30	2/30	2/30	
Height difference of the installation		Outdoor unit above / below	m	20	20	20
Sound pressure level (1m)	Outdoor unit	dB	43	44	45	
	Indoor unit	dB	28	28	29	
Net dimensions (length x height x width)	Outdoor unit	mm	350 x 700 x 900	350 x 700 x 900	395 x 805 x 970	
	Indoor unit	mm	420 x 790 x 270	420 x 790 x 270	420 x 790 x 270	
Packaging dimensions (length x height x width)	Outdoor unit	mm	430 x 770 x 1020	430 x 770 x 1020	495 x 895 x 1105	
	Indoor unit	mm	515 x 985 x 355	515 x 985 x 355	515 x 985 x 355	
Net weight / gross weight	Outdoor unit	kg	51 / 55	51 / 55	65 / 69	
	Indoor unit	kg	38 / 44	38 / 44	39 / 45	
Range of operation in external temperatures	Cooling	°C	10 ~ 48	10 ~ 48	10 ~ 48	
	Heating	°C	-25 ~ 35	-25 ~ 35	-25 ~ 35	
	CWU	°C	-25 ~ 43	-25 ~ 43	-25 ~ 43	
Water supply temperature range	Cooling	°C	5 ~ 25	5 ~ 25	5 ~ 25	
	Heating	°C	25 ~ 65	25 ~ 65	25 ~ 65	
	CWU	°C	30 ~ 60	30 ~ 60	30 ~ 60	

We reserve the right to errors in descriptions, appearance, functions, technical parameters, and dimensional drawings resulting from the continuous improvement of our devices.

ACHP-H10/4R3HA			ACHP-H12/5R3HA			ACHP-H14/5R3HA			ACHP-H16/5R3HA		
ACHP-H10/4R3HA-O			ACHP-H12/5R3HA-O			ACHP-H14/5R3HA-O			ACHP-H16/5R3HA-O		
ACHP-H10/5R3HA-I			ACHP-H12/5R3HA-I			ACHP-H14/5R3HA-I			ACHP-H16/5R3HA-I		
Dual rotary DC Inverter			Dual rotary DC Inverter			Dual rotary DC Inverter			Dual rotary DC Inverter		
Brushless DC motor			Brushless DC motor			Brushless DC motor			Brushless DC motor		
1			1			1			1		
1,45			1,84			1,84			1,84		
Electronic			Electronic			Electronic			Electronic		
Φ9.52/15.9			Φ9.52/15.9			Φ9.52/15.9			Φ9.52/15.9		
2/30			2/30			2/30			2/30		
20			20			20			20		
48			49			50			54		
29			31			31			31		
395 x 805 x 970			420 x 860 x 990			420 x 860 x 990			420 x 860 x 990		
420 x 790 x 270			420 x 790 x 270			420 x 790 x 270			420 x 790 x 270		
495 x 895 x 1105			530 x 880 x 1085			530 x 880 x 1085			530 x 880 x 1085		
515 x 985 x 355			515 x 985 x 355			515 x 985 x 355			515 x 985 x 355		
65 / 69			88 / 94			88 / 94			88 / 94		
39 / 45			39 / 45			39 / 45			39 / 45		
10 ~ 48			10 ~ 48			10 ~ 48			10 ~ 48		
-25 ~ 35			-25 ~ 35			-25 ~ 35			-25 ~ 35		
-25 ~ 43			-25 ~ 43			-25 ~ 43			-25 ~ 43		
5 ~ 25			5 ~ 25			5 ~ 25			5 ~ 25		
25 ~ 65			25 ~ 65			25 ~ 65			25 ~ 65		
30 ~ 60			30 ~ 60			30 ~ 60			30 ~ 60		

We reserve the right to errors in descriptions, appearance, functions, technical parameters, and dimensional drawings resulting from the continuous improvement of our devices.

Model name		ACHP-H04/4R3HA	ACHP-H06/4R3HA	ACHP-H08/4R3HA	
Outdoor unit		ACHP-H04/4R3HA-O	ACHP-H06/4R3HA-O	ACHP-H08/4R3HA-O	
Indoor unit		ACHP-H04/4R3HA-I	ACHP-H06/4R3HA-I	ACHP-H08/5R3HA-I	
Water circulation	Water connection	cale	R1"	R1"	
	Safety valve setting	MPa	0,3	0,3	
	Minimum water flow	m³/h	0,36	0,36	
	Expansion vessel	Capacity	L	8	8
		Max water pressure	MPa	0,3	0,3
	Type of water heat exchanger	-	Plate	Plate	
	Flow electric heater	kW	3	3	
	The height of the water pump lift	m	9,5	9,5	

We reserve the right to errors in descriptions, appearance, functions, technical parameters, and dimensional drawings resulting from the continuous improvement of our devices.

Model name		ACHP-H10/4R3HA	ACHP-H12/5R3HA	ACHP-H14/5R3HA	ACHP-H16/5R3HA	
Outdoor unit		ACHP-H10/4R3HA-O	ACHP-H12/5R3HA-O	ACHP-H14/5R3HA-O	ACHP-H16/5R3HA-O	
Indoor unit		ACHP-H10/5R3HA-I	ACHP-H12/5R3HA-I	ACHP-H14/5R3HA-I	ACHP-H16/5R3HA-I	
Water circulation	Water connection	R1"	R1"	R1"	R1"	
	Safety valve setting	0,3	0,3	0,3	0,3	
	Minimum water flow	0,36	0,6	0,6	0,6	
	Expansion vessel	Capacity	8	8	8	8
		Max water pressure	0,3	0,3	0,3	0,3
	Type of water heat exchanger	Plate	Plate	Plate	Plate	
	Flow electric heater	9	9	9	9	
	The height of the water pump lift	9,5	9,5	9,5	9,5	

We reserve the right to errors in descriptions, appearance, functions, technical parameters, and dimensional drawings resulting from the continuous improvement of our devices.

DIMENSIONAL DRAWINGS

Outdoor unit 4 kW, 6 kW

ACHP-H04/4R3HA-O
ACHP-H06/4R3HA-O

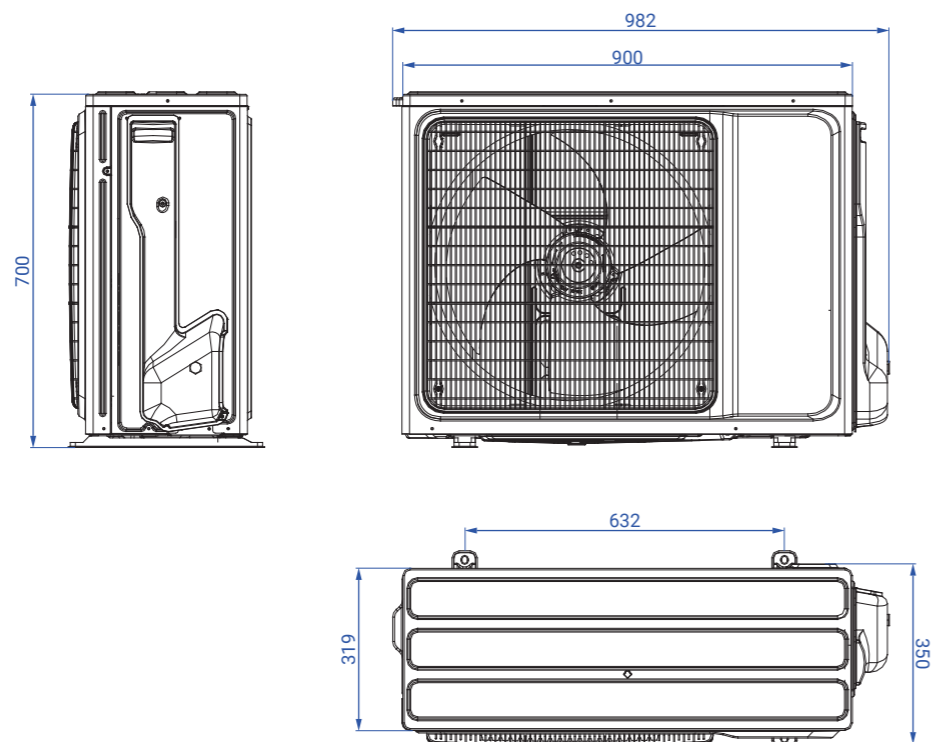

Outdoor unit 8 kW, 10 kW

ACHP-H08/4R3HA-O
ACHP-H10/4R3HA-O

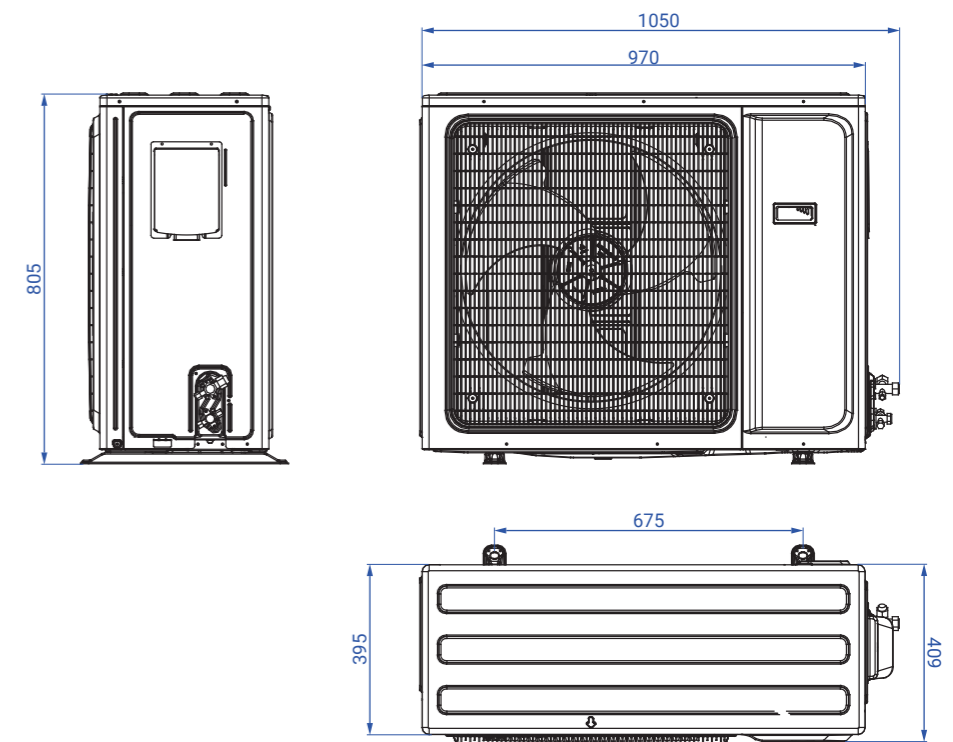

We reserve the right to errors in descriptions, appearance, functions, technical parameters, and dimensional drawings resulting from the continuous improvement of our devices.

We reserve the right to errors in descriptions, appearance, functions, technical parameters, and dimensional drawings resulting from the continuous improvement of our devices.

Outdoor unit
12 kW, 14 kW, 16 kW

- ACHP-H12/5R3HA-O
- ACHP-H14/5R3HA-O
- ACHP-H16/5R3HA-O

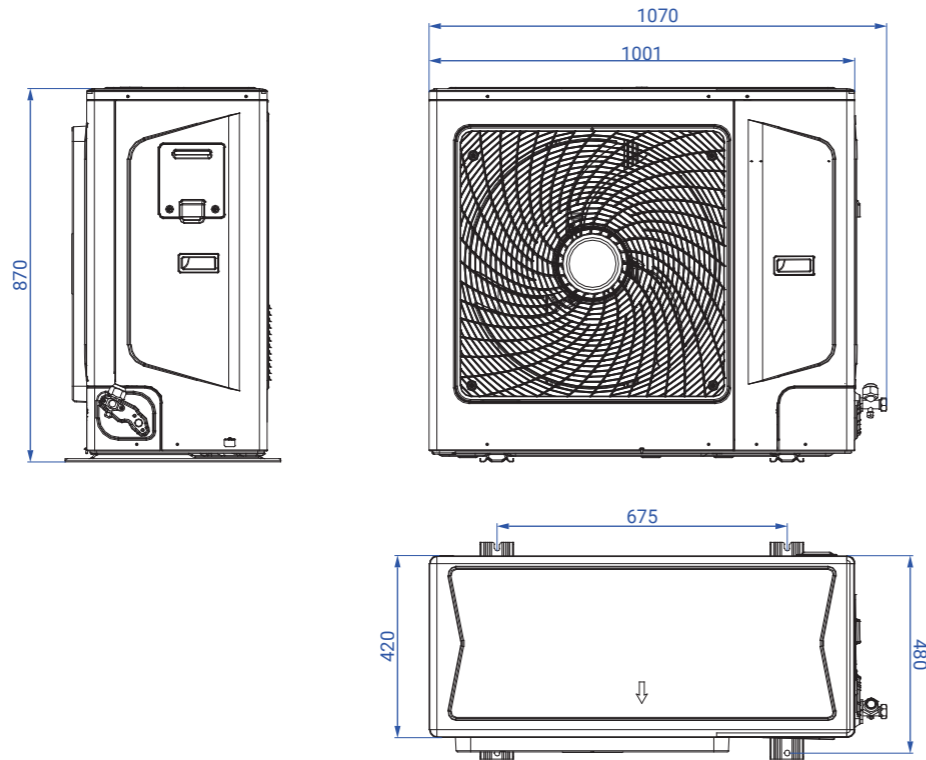

Indoor unit

- ACHP-H04/4R3HA-I
- ACHP-H06/4R3HA-I
- ACHP-H08/5R3HA-I
- ACHP-H10/5R3HA-I
- ACHP-H12/5R3HA-I
- ACHP-H14/5R3HA-I
- ACHP-H16/5R3HA-I

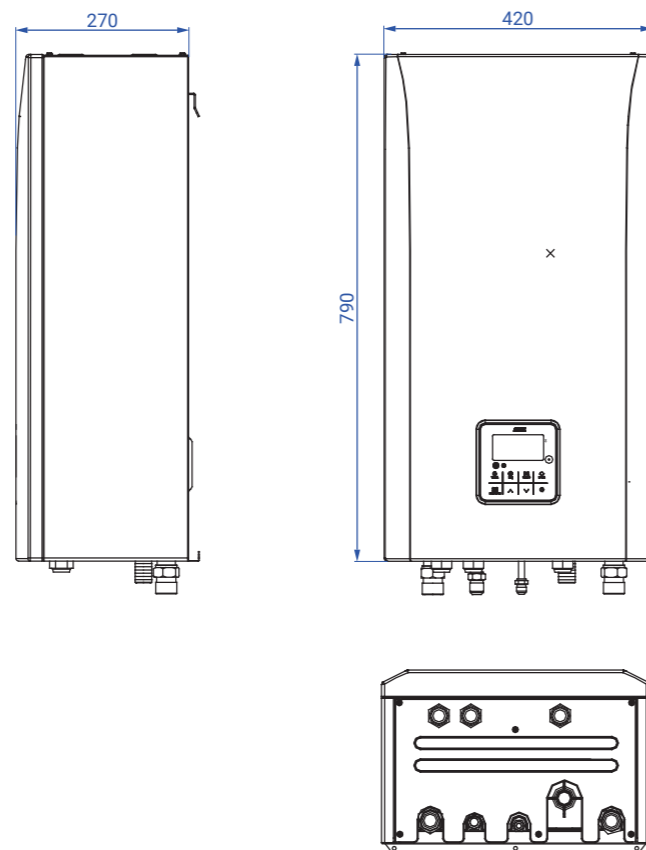

AUX cares for the natural environment

YOUR TRUSTED
PARTNER IN BUSINESS

We are committed to improving living conditions and comfort, which is why our offer includes a full range of air conditioning devices and systems dedicated to individual clients, small businesses, as well as large institutional clients.



**Warranty and
post-warranty
service**



**Commissioning
and startup of
devices**



**Design
and technical
consulting**



**Delivery
of equipment**

WWW.WIENKRA.PL

We are the **exclusive distributor** of the AUX brand in Poland!
We invite you to visit our branches.

WE ARE
AT YOUR DISPOSAL

We have delivered over one million air conditioners to our customers, as we have been working continuously for 30 years with global leaders in air conditioning device production. Therefore, we are confident that we offer products and solutions of the highest quality, incorporating the latest technologies, meeting high standards in terms of energy efficiency, design, and ecology.



Cracow:

- 📍 34 Kotlarska street, 31-539 Cracow
- 📍 20g Rzemieslnicza street, 30-347 Cracow
- ☎ +48 12 428 55 00
- ✉ wienkra@wienkra.pl

Warszawa - Janki:

- 📍 15 Sokolowska street, 05-090 Janki
- ✉ wienkra-waw@wienkra.pl

Wroclaw:

- 📍 61 Armii Krajowej avenue, 50-541 Wroclaw
- ✉ wienkra-wro@wienkra.pl

AUX HEAT PUMPS



WIENKRA

WIENKRA Sp. z o.o.

Exclusive Distributor of the AUX brand in Poland:

Cracow:

📍 34 Kottarska street, 31-539 Cracow
📍 20G Rzemieslnicza street, 30-347 Cracow
✉️ wienkra@wienkra.pl

Warsaw - Janki:

📍 15 Sokolowska street, 05-090 Janki
✉️ wienkra-waw@wienkra.pl

Wroclaw:

📍 61 Armii Krajowej Avenue, 50-541 Wroclaw
✉️ wienkra-wro@wienkra.pl

www.auxcool.com

 [auxaurope](https://www.facebook.com/auxaurope)